







**TRITHONSPORT**  
WWW.TRITHON.DK

**Manual for  
SIZE 2100x800 wall bars**

**Necessary equipment for installation:**

Electric screwdriver - wall driller	Concrete 12mm drill	Drill bit T25	Hammer or rubber hammer	Wrench 13mm
				

**Package includes:**

- ! Side parts 2pcs
- ! Bars with drilled holes 3pcs
- ! Bars 12pcs
- ! Screw A1 6pcs
  
- ! Screw with dowel A4 6pcs:



- ! Bouncing board ( for safety using hammer).

### Manual . Step by step:

1. Take one side part, place it to the clean , flat floor. Start with 3 bars that have drilled holes. Place them in sockets with drilled holes. Bounce with hammer

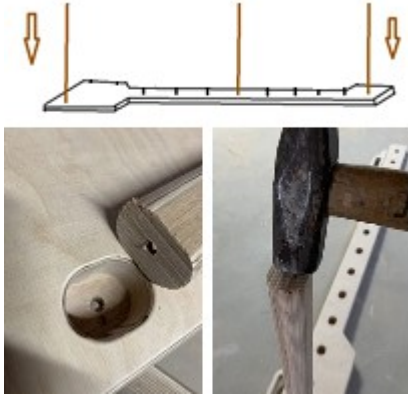

(drilled holes) and put them in sockets . Bounce

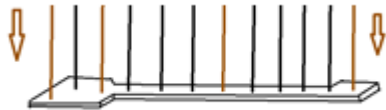

3. Put on the second side part.

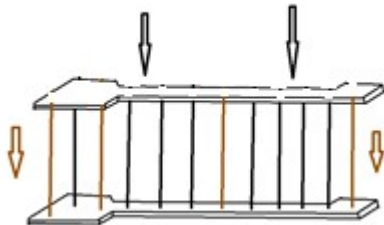

4. Use BOUNCING BOARD and hammer to hit parts together.



5. Screw together with A1 screws and electric screwdriver from both sides of side parts:



6. Make marks on the wall – copy them from left side (inside), copy them from right side (outside): those will be the centers for drill holes, drill (with 12mm drill) holes 60mm deep, hit in plastic dowel, use screw A4 with electric screw driver, in the finish use wrench 13mm to screw the nut.



Installation is done.

**Good luck and enjoy your activities.**